

"FVA-M2ST" is a biometric authentication module which uses finger vein patterns to authenticate individuals to provide high-level security. Module has versatility to be embedded into other devices easier than ever.



### Features of FVA-M2ST

#### Versatility

"FVA-M2ST" has versatility to various system devices as finger vein patterns used for authentication will be encrypted and stored outside module.

#### Convenient

Light in weight and compact, this finger vein authentication module can be embedded in various devices and places. This module has 2 I/F, which are USB and RS-232C to expand its suitable control for your needs.

#### Comfort

"mofiria" has comfortable, fast and high-accuracy authentication process by using original authentication algorithm to reduce stress from the traditional authentication system.

### How FVA-M2ST Works

- Generate near-infrared lights on a finger and capture scattered lights with a sensor to recognize finger vein pattern.
- Capture the finger vein patterns to enroll to process authentication by using captured finger vein patterns.
- Authentication process completes when scanning same finger vein patterns captured above is matched with enrolled patterns.

This product is designed and produced for general office usage purposes. Please avoid using this product for purposes that may affect your life or property.

## What is finger vein authentication?

Finger vein authentication is one of the biometrics authentication methods to scan finger vein patterns to identify individuals.

### Features of vein pattern authentication

- Vein patterns vary from individual to individual. This will provide high-accurate and secure individual authentication.
- Assures stability for long-term use since vein patterns do not change across the ages.
- Because finger veins are located inside human body, forgery or identity theft is nearly impossible and achieve favorable authentication accuracy compared to other biometric authentication methods.

### ■ What is finger vein authentication technology “mofiria”

“mofiria” is unique finger vein authentication technology having small, fast, high-accuracy and comfortable operability.

#### Small



“mofiria” adopts a unique reflective dispersion method, which near-infrared lights at the finger veins generated by LED will be reflected inside the finger, and capture the image with CMOS sensor. Since LED light generation and image captured by CMOS sensor are done diagonally, unit is designed for plane arrangement, compact and flexible design embedded to other devices.

#### Fast

In addition to a fast and accurate finger vein pattern scanning method, “mofiria” uses an automatic and simultaneous finger position adjustment technology to achieve high-speed authentication.

#### Comfortable

By our unique algorithm, automatic finger position adjustment ensures both comfortable operability and high accuracy authentication without firmly fixing the finger position on the unit.

### ■ Product Specification

Voltage / Current	Authentication Mode : DC 5V / 250 mA or less
Power supply	USB Bus power or DC5V (RS232C Interface) +/- 10%
Operating Temperature	+5°C~+50°C (41°F~122°F)
Operating Humidity	20%~80% (No condensing)
Operating Illuminance	3,000 lux or less (with fluorescent lamp)
Stored Temperature	-20°C~+60°C (-4°F~+140°F)
Stored Humidity	10%~90% (No condensing)
OS Requirements	Depends on supported OS by mofiria’s software development kits compatible with this device (Windows, macOS, Android, Linux and so on)
System Requirements	USB : USB2.0 Full Speed, RS232C: whichever having interface feature of Baud rate 115.2kbps. * Choose either one of both interfaces to connect.
Size	Approx. 76 × 65 × 45.3mm (W/H/D)
Weight	Approx. 32 g

FVA-M2ST is compatible with FVA-M1ST and FVA-OA11 at the systems sharing finger vein templates.

Please check operations before using the product. Please note that regardless of warranty term, the warranty does not cover any kind of loss in your business caused by defects and/or malfunctions in this device.

### What “mofiria” can do?

Devices with “mofiria” technology which has characteristics of portability will give a “versatility” to embed various types of mobile products and will expect security improvement for various business scenes.



### ■ Size (mm)

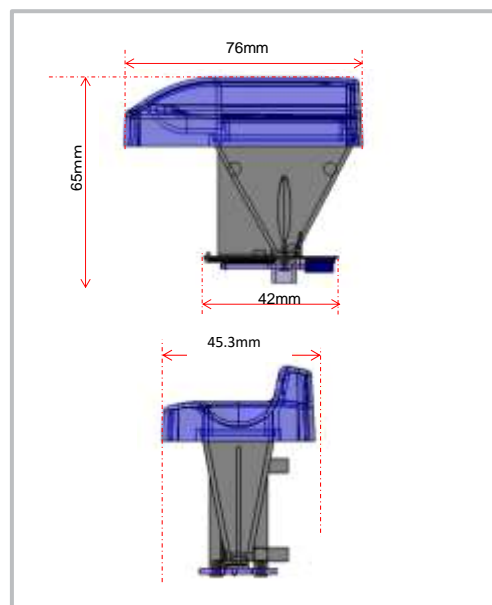

#### ⚠ Safety Notice

Please read the Instruction Manual carefully before using the product.

- Design and specifications are subject to change without notice.
- Colors displayed in the catalog may slightly vary from the actual product color due to printing issues.
- Windows and Windows Vista are registered trademarks of Microsoft Corporation in the United States and/or other countries.
- In addition, system and products name used in this manual are, in general, trademarks or registered trademarks of their respective owners. However, the TM or ® marks are not used in all cases in this manual.

“mofiria” Website

<https://www.mofiria.com/en>

#### mofiria Corporation

Selavi Gotanda Bldg 7F 2-13-6 Nishi-Gotanda Shinagawa-ku, Tokyo 141-0031 Japan

Please contact mofiria Corporation for any question about this product.

Mail : [info@mofiria.com](mailto:info@mofiria.com)